

RoHS

Mark	ECN NO.	DESCRIPTION	DESIGN	Date:

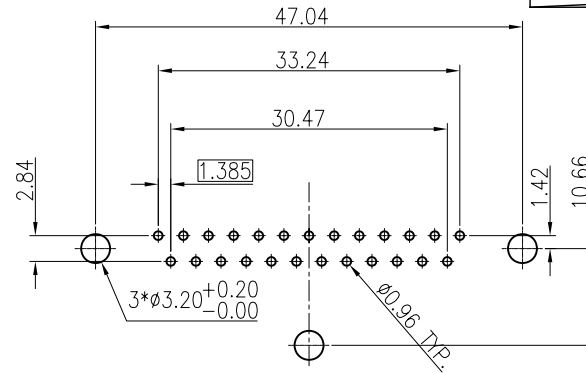

P.C.B. LAYOUT(TOP VIEW)

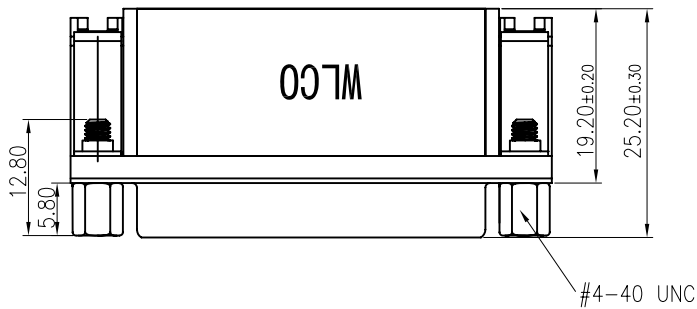
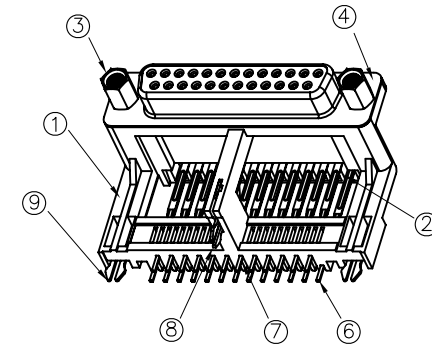
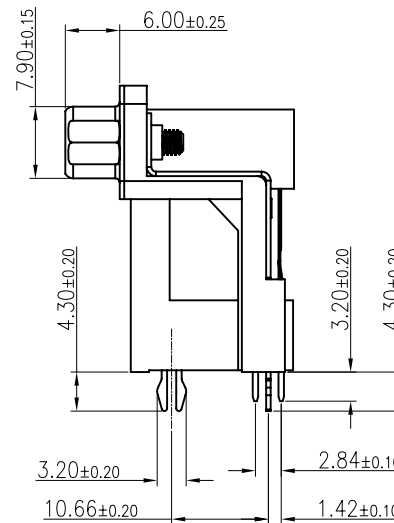
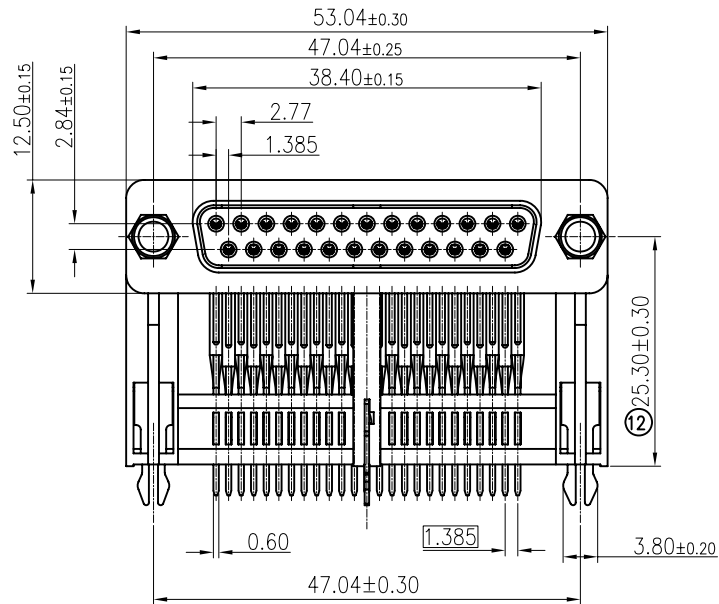

SCALE: 1:2

备注:
 外观: 无变形, 脏污, 划伤及其它明显缺陷;
 商标清晰, 颜色符合要求;
 尺寸: 未注公差参照公差表;

8	BOARDLOCK	22-03-0003-1	2	SPCC	NICKLE
7	BOARDLOCK-M	22-03-0004-1	1	SPCC	NICKLE
6	短端	22-01-0014-1	12	SK7	Sn/Au/Ni
5	长端	22-01-0013-1	13	SK7	Sn/Au/Ni
4	SHELL	26-03-0005-1	1	SPCC	NICKLE
3	螺丝	26-03-0003-1	2	COPPER ALLOY	NICKLE
2	盖子	22-07-0004-1	1	PBT+30%GF	
1	主体	22-06-0006-1	1	PBT+30%GF	
ITEM	PART	P/N (NEW)	QTY.	MATERIALS	REMARK

Tolerance X.X ±0.30 X.XX ±0.25 X.XXX ±0.15 Angle ±2.0°	Model Name: DR 25母 深紫色 高架 (直锁5.8螺丝) 铁端子			Drawing: ZengL
	Model No: WLDR-045A			Checked: Lijian
	UNIT: mm	SCALE: FULL	REVISION: A1	Approved: WEI JI YANG
	SHEET: 1/1			Date: 2011.08.04
DWG NO.		FILE: C		

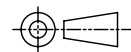

WLCO[®] 深圳市兴万联电子有限公司
 SHENZHEN XINGWANLIAN TECHNOLOGY CO., LTD